

DIAMOND ANTENNA

HV7A Mobile Antenna System

General Information

HV7A has 5 band capability—6m/2m/70cm, plus 2 HF bands though use of loading coils. The HV7A is supplied with HVC28 (10m) loading coil. There are four optional HF coils available: HVC7 (40m), HVC14 (20m), HVC18 (17m), and HVC21 (15m). The HV7A has a fold-over structure which allows for entrance into parking structures (i.e. garages, buildings, etc.). Use DIAMOND model MX62M Duplexer for single antenna operation with ICOM IC-706 series, Yaesu FT100 or for combining HF & VHF transceivers.

Bands Supplied
Power, PEP:
Mount Connection:
Length:
VSWR:
Frequency:
(Nominal BW)

Specifications

10m/6m/2m/70cm
HF 120 watts / VHF 200 watts
UHF
54" (with the HVC7 installed, total length is 80")
1.5:1 Nominal—HV7A (10m/6m/2m/70cm)
6m: 50-54 MHz; 2m: 144.5-148 MHz; 70cm: 440-450 MHz
HVC7 (40m): (28 KHz)
HVC14 (20m): (60 KHz)
HVC18 (17m): (140 KHz)
HVC21 (15m): (180 KHz)
HVC28 (10m): (390 KHz)
6m— $1/4\lambda$, 2m— $5/8\lambda$, 70cm— $2-5/8\lambda$
Diamond K400C or K600M
Diamond MX62M

Element Phasing:
Recommended Antenna Mounts:
Recommended Duplexer:

Installation Instructions

PRECAUTIONS:

- (1) The HV7A requires vehicle ground.
- (2) If installing HVC7 (40m) loading coil, install on top (vertical position) only. Some installations may require a nylon fish line to relieve stress on vehicle mount.
- (3) The HV7A 6m/2m/70cm tuning assumes that at least one loading coil is mounted at the top end. VSWR may be out of specification without the coil(s).

- (1) Choose mounting location to insure maximum strength of mount, and proper vehicle ground to yield best performance.
- (2) Assemble HV7A with desired loading coil and install on vehicle mount. (HVC28 10m coil is included in package.)

NOTE: Metric Hex wrenches are enclosed.

READ THIS BEFORE TUNING ANTENNA:

Included are two 6" pieces of 16ga copper wire to assist in tuning antenna coils. Use copper wire in place of original tuning elements to simplify tuning process. Once proper tuning is achieved, trim original steel elements to their desired length and verify adjustment.

Tuning the HV7A Antenna:

- 3) **NOTE:** You must tune 6-meter band before adjusting the HF coils. Always check upper and lower bandwidth edges with quality VSWR meter before trimming tuning elements. (Omit 6m portion if not to be used.)

Replace the stock 6m tuning element with one of the enclosed 6" copper wire. The element can be replaced by loosening setscrew on element support bracket #981116. It is important to leave additional 1/2-3/4" below support bracket for additional adjustment.

(See Illustration).

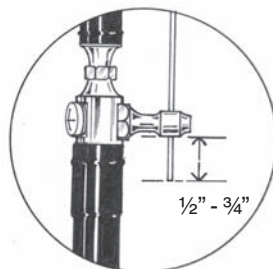

HVC28/10m Loading Coil

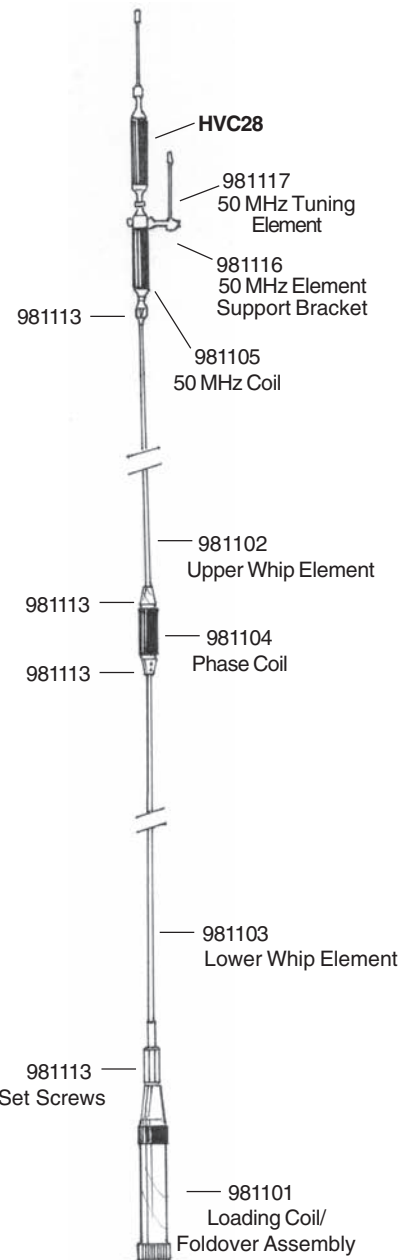
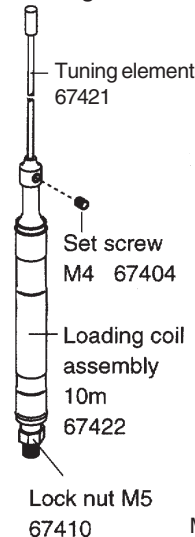

With quality VSWR meter, check VSWR on lower portion of 6m (50.150 MHz). Tune the copper rod by trimming from top in 1/8" increments only until lowest VSWR is obtained. Shortening extension element will have effect of raising the resonant frequency.

You may have to re-adjust the VSWR on 6m band when using additional HVC loading coils. Do not re-install original 6m tuning element until trimming of all HVC loading coils is finished. This will allow for any additional adjustment that may be necessary.

(4) When tuning optional loading coils (HVC7, HVC14, HVC18, HVC21 and HVC28 (enclosed in package), install on top (vertical position) and proceed to tune the coils. Replace original tuning element with enclosed copper wire. Install copper wire into HVC loading coil until it seats at the bottom. NOTE: HVC loading coils have a limited tuning range – refer to “frequency” under specifications for bandwidth.

Choose your desired center frequency and trim for best VSWR. Simply trim the copper wire from the top in 1/8" increments until desired center frequency is achieved.

(5) Once you have adjusted all coils for best VSWR in the vertical position, you may assemble one optional coil horizontally. It is best to use the lowest frequency coil in the vertical position. All coils can work horizontally except the HVC7 (40m); it must be in the vertical position due to its size. The horizontal coil should point to the rear. The VSWR will change slightly by adding a coil horizontal; therefore, it is best to check your VSWR readings to verify adjustment.

To add loading coil in horizontal position, simply remove Philips head screw from opposite side of #981116 (50 MHz Element support bracket) and screw HVC coil into position. (See Illustration) All HVC loading coils have lock nut on threaded end to aid in fastening coil into position.

NOTE: Do not dispose of Philips head screw, as you may need it for future use.

(6) To replace HVC loading coils, simply unscrew from 50 MHz coil and replace with another using 10mm wrench for base of 50 MHz coil, and 8mm wrench for lock nut on HVC loading coils. (See Illustration) Be sure loading coils are fastened securely so they don't loosen from vehicle and road vibration.

(7) After all tuning and adjustments have been made, you can remove the trimmed copper wire from the 50 MHz support bracket and the HVC loading coils and trim the original steel tuning elements to exact length of copper wire. Re-install in proper position and re-check VSWR.

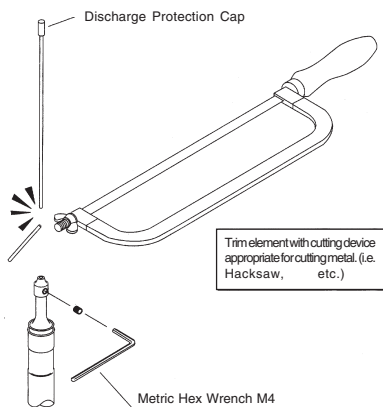

(8) The HV7A has a fold-over hinge for situations where the antenna height is a problem. (See Illustration) Simply unscrew the fold-over lock, LIFT UP, and tilt over 90°. Care should be taken when folding over, not to damage vehicle or any HVC loading coils. Do not drive with antenna in the folded position.

Adjustment element length vs. frequency change on each frequency band.

Frequency	change
40m	approx. 40kHz per 1cm
20m	approx. 70kHz per 1cm
17m	approx. 220kHz per 1cm
15m	approx. 250kHz per 1cm
10m	approx. 360kHz per 1cm

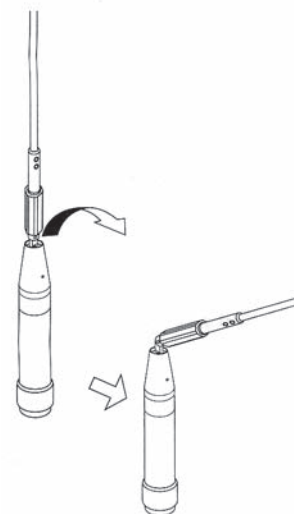
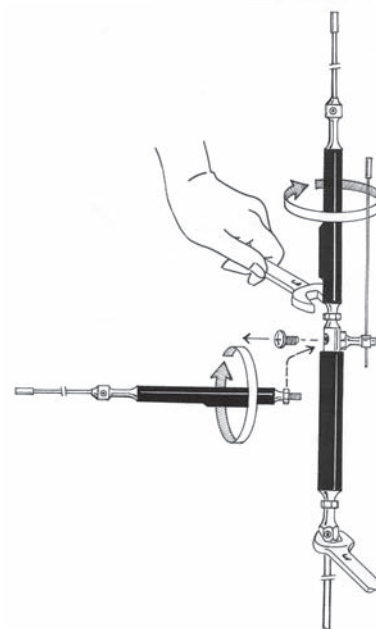
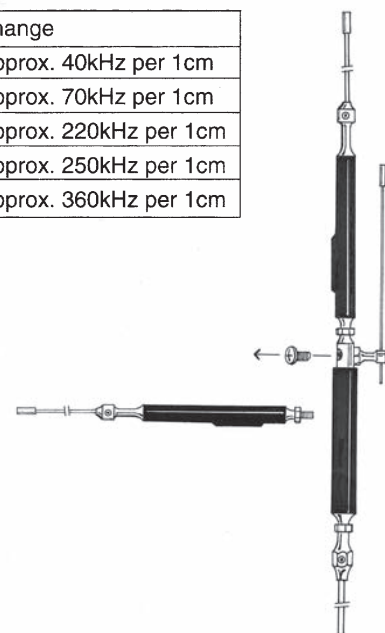

Typical VSWR Charts

6M/50 MHz

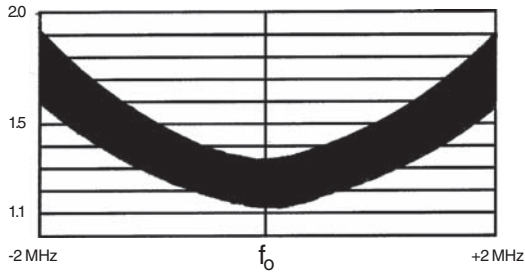

<40m> HVC7

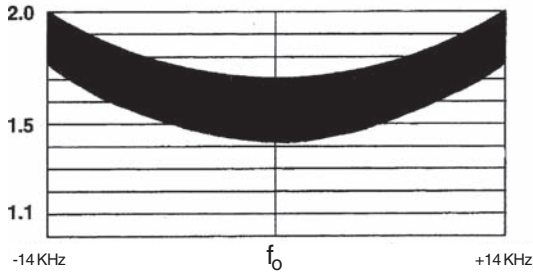

<20m> HVC14

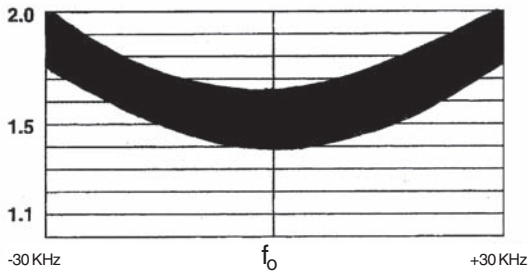

<15m> HVC21

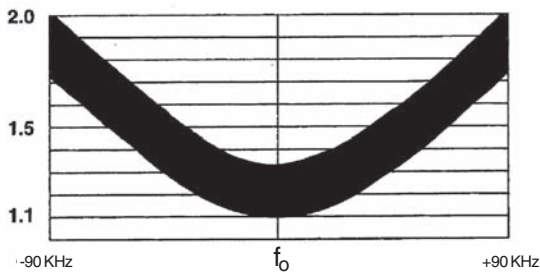

<17m> HVC18

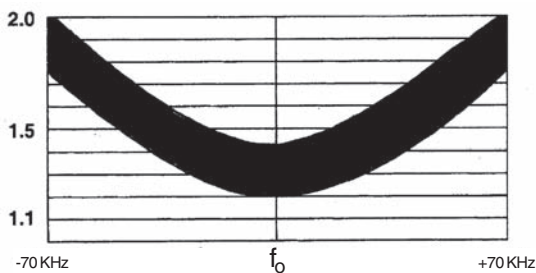

<10m> HVC28

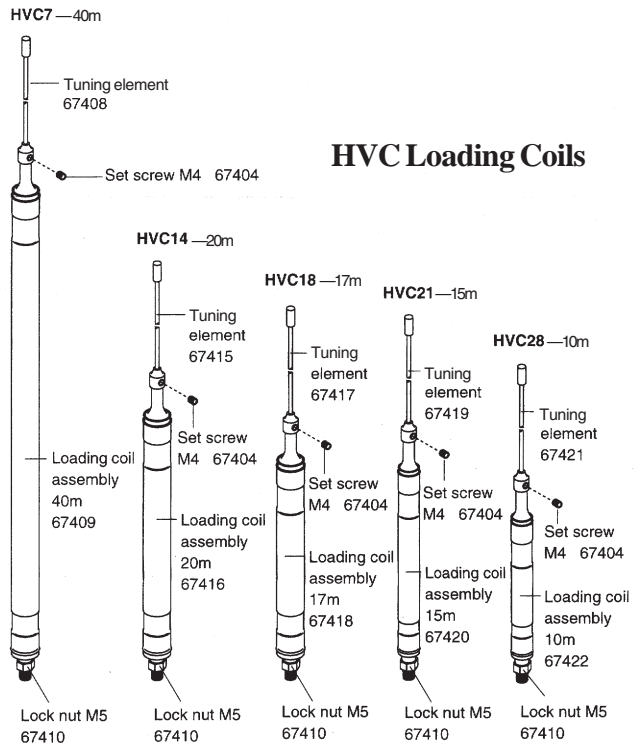

WARNINGS:

- (1) Bolts and set screws on antenna and mounting bracket may loosen from vehicle and road vibration. Be sure to check periodically to ensure they are fastened securely.
- (2) Avoid obstacles such as tree branches or low overpasses; impact with these obstacles will cause antenna damage.
- (3) The HV7A is not recommended for either magnet type mounts or installation on large GVW vehicles.
- (4) Avoid touching antenna while transmitting.
- (5) Do not scratch or remove rubber covering on loading coil sections.
- (6) Avoid driving with antenna in folded position.

<10m> HVC28

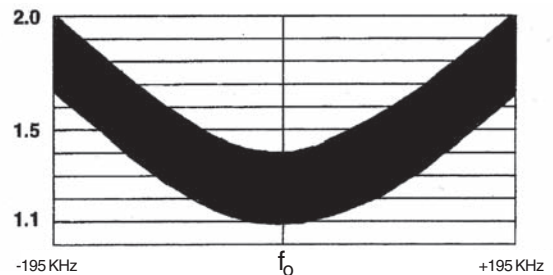

HF Mobile Installation Tips

With all the different types of installations possible, there are many unique problems that can occur. We have compiled some additional notes on specified areas.

- (1) **GROUNDING ANTENNA:** Obtaining a good ground is very important to any HF mobile installation. No matter where your antenna is mounted, it is highly recommended you run a heavy copper strap or braid (1" to 3") between body and frame of your vehicle. (NOTE: Copper wire is not sufficient!) If you have ignition noise problems, it is also recommended to ground the end of your tail pipe to the frame.¹
- (2) **OPTIMUM MOUNTING LOCATION:** You should always mount your antenna as high on your vehicle and as far away horizontally from other metal objects as possible. The center of your roof is the best location; however, this is seldom practical or possible for most HF antenna installations. The next best location is in the center of the driver's side of the trunk lid (mounting on driver side to avoid low hanging curbside branches or objects). The DIAMOND K400C and K600M series mounts work well with the HV7A.
- (3) **TRUNK LID MOUNTING:** Probably the best mounting location for most vehicles. Usually, adding one or two copper straps from the hinge area to car body will improve grounding (and thereby antenna tuning). It is necessary that at least two of the four sockethead screws on mount penetrate paint to metal for proper grounding. (A little clear nail polish or other acrylic paint may be used to seal around mounting screws.)
- (4) **COAX:** If you use an antenna mount other than DIAMOND ANTENNA models K400C or K600M, it is very important to use a quality 52 ohm coax (RG8U, RG58U, RG213, RG316, Teflon Coax, etc., with at least 95% shield).
- (5) **EMI:** Electromagnetic Interference is the single greatest concern for HF mobile applications. Route your cable as far from the vehicles ECM (Engine Control Module) and vehicle's electrical systems as possible. Sometimes a ferrite (clamp) choke may be required on coax near mount. There are many books on the subject of interference, refer to endnotes for additional information.²

1. J. Seybold, "HF Mobile Installation Tips", December 1995 QST, pg. 58-60.

2. ARRL, Radio Frequency Interference Tips: How to find it and fix it., The book is available from your favorite amateur radio dealer or ARRL headquarters.

WARNING! PLEASE READ BEFORE INSTALLATION

BASE STATION ANTENNA DIAMOND base station antennas are pre-tuned to give best performance on the band(s) for which they are designed, and no further adjustment should be attempted. Exception: DPGH62 & V2000A require 6m tuning. CP6 & CP6A have tuning instructions included.

BASE ANTENNAS HAVING TYPE-N CONNECTOR Care should be taken to avoid damage of the center pin of antennas having "TYPE-N" base connector. Attempted connection of a PL-259 (UHF) or improperly assembled "N" cable connector can damage the antenna connector. Damage to the antenna connector is not covered by warranty.

MOBILE ANTENNA For ease of installation, DIAMOND ANTENNA MOBILE MOUNTS are strongly recommended. In some cases, mobile mounts of different manufacture may not interface well with DIAMOND Antennas. DIAMOND Mobile antennas are pre-tuned to give best possible performance on the band(s) for which they are designed. In some installations, minor VSWR adjustment may be made by moving the antenna up/down at the base end. Two set screws at the base allow for adjustment. Do not cut the antenna rods. Use of magnet mounts is not recommended with tall antennas, i.e. SG2000HD, SG7900, CR627B, & HV7A, etc. Excessive VSWR may occur with the following antennas if used on a magnet mount: CR320A, NR72BNMO, SG-M911, and SG7000A.

LARGE GVW TRUCK AND OFF ROAD VEHICLES Due to the excessive vehicle vibration, antennas exceeding 45" are not recommended. In any event, antennas damaged by excessive vibration are not covered by warranty.

Any tampering, cutting, or attempted adjustment of this antenna beyond our recommendations may void all warranty. If you have any questions, please call Diamond Customer Service Dept. at (760) 744-0900.

HV7A Accessory Items

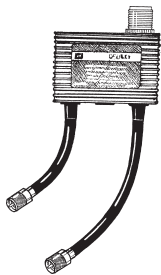

MX62M Duplexer

LPF 1.6-56; HPF 76-470
Power; 200w CW, 600w PEP
Connectors: Mix-UHF(F);
Ports-UHF(M) w/12" cable



K400C

Trunk/Hatchback Mount

Deluxe UHF type base
Dual-axis adjustable
6½' RG316 Teflon Coax w/PL-259.
Use Diamond Model C110 for front radio installations.

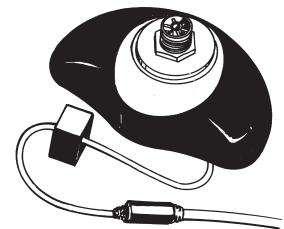

K600M

Trunk Mount

Deluxe trunk mount.
16.5' RG188 and 7mm 5D Coax.
Adjustable Tilt Angle (0-9°)

DIAMOND ANTENNA Products are distributed by RF PARTS COMPANY

435 S. Pacific Street • San Marcos, CA 92078 • (760) 744-0900

www.diamondantenna.net